



APEX DYNAMICS, INC.

**HIGH PRECISION
HIGH SPEED
PLANETARY GEARBOX**

AD / ADR / ADS Series



Stainless



Apex Dynamics, Inc. is the world's most productive manufacturer of servomotor drive planetary gearboxes for precision automation machinery. From our 800,000+ square foot ISO 9001:2008 manufacturing facility, based in Taichung, Taiwan, we manufacture to stock using the newest precision machine tools and quality test and inspection equipment. Complete focus on quality and precision allows us to produce our high quality gearheads at precision levels down to less than 1 arc minute (1/60 th of a degree), with consistency and high reliability.

Based on more than twenty years of accumulated manufacturing and marketing experience, plus the highest level of technical production capabilities, Apex Dynamics, Inc. designs and builds technically advanced, high speed, low backlash servo application planetary gearboxes. Our Break through patented technology (over 6 patents), provides the customer with the optimum high precision helical reducer at a reasonable price. We are continuously improving processes, finding proper and effective methods to provide customers new solutions for difficult applications, and developing new products.

The primary focus in daily operation is quality. We pride ourselves on our dedication to quality; our duty - is customer satisfaction.



AD Series Ordering Code

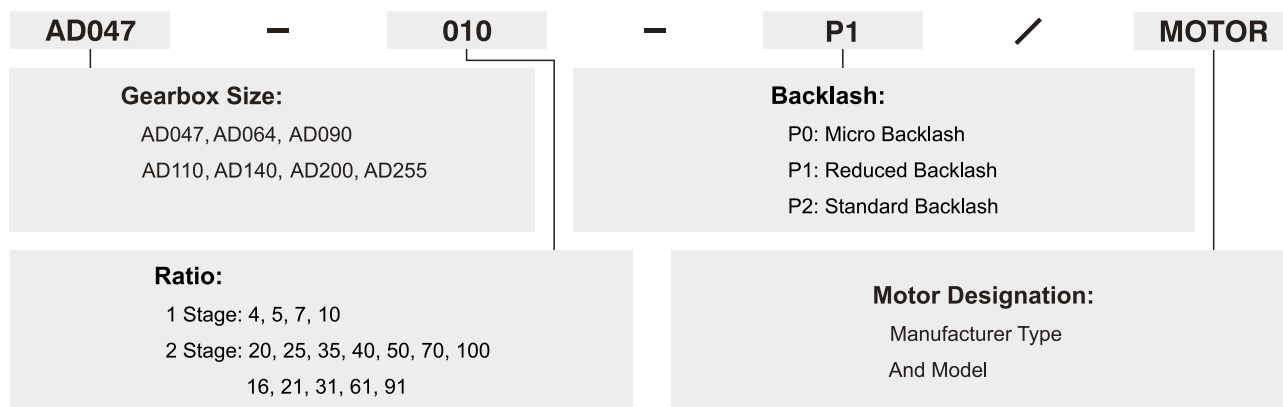

Ordering Example: AD047-010-P1 / SIEMENS 1FT6 041-4AF71

ADR Series Ordering Code

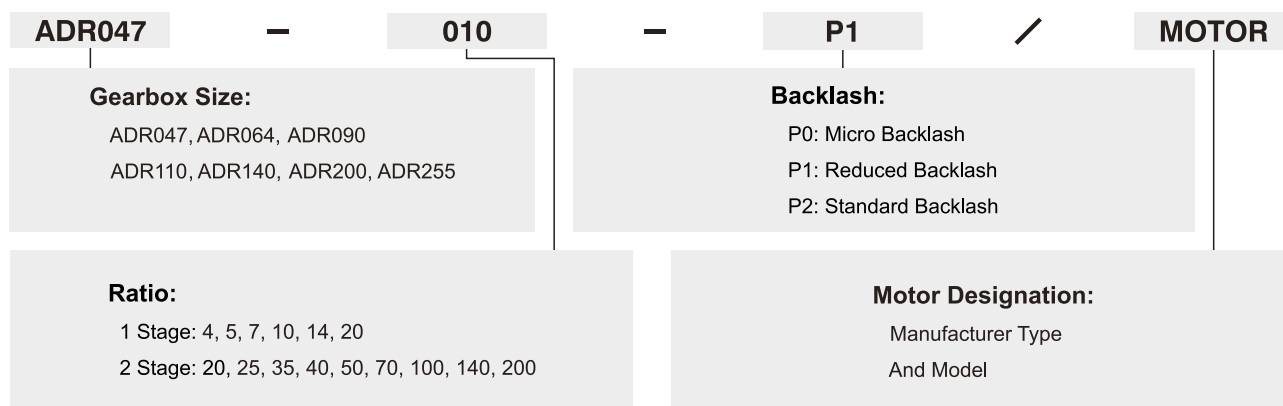

Ordering Example: ADR047-010-P1 / SIEMENS 1FT5 034-OAK71

ADS Series Ordering Code

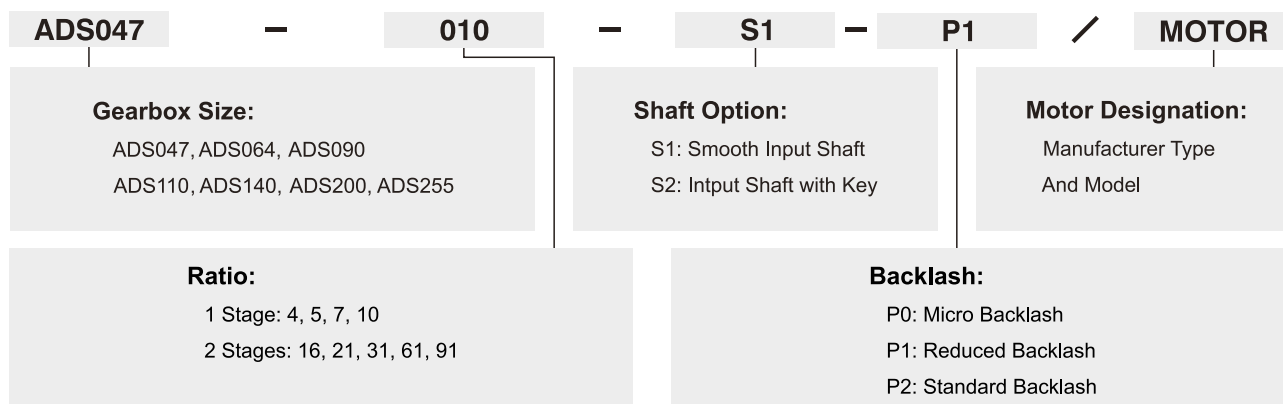

Ordering Example: ADS047-010-S1-P1 / SIEMENS 1FT5 034-OAK71



©2019 by APEX DYNAMICS, INC.
 APEX DYNAMICS, INC. reserves modification and copyrights of all technical specifications, illustrations and drawings in this catalog in allowance for continuous products development and advancement.
 For the newest data and information, please visit <http://www.apexdyna.com/>

Specifications / AD Series

Gearbox Performance

Model No.		Stage	Ratio ⁽¹⁾	AD047	AD064	AD090	AD110	AD140	AD200	AD255
Nominal Output Torque T_{2N}	Nm	1	4	19	48	130	270	560	1,100	1,700
			5	22	60	160	330	650	1,200	2,000
			7	19	50	140	300	550	1,100	1,800
			10	14	40	100	230	450	900	1,500
		2	20	19	48	130	270	560	1,100	1,700
			25	22	60	160	330	650	1,200	2,000
			35	19	50	140	300	550	1,100	1,800
			40	19	48	130	270	560	1,100	1,700
			50	22	60	160	330	650	1,200	2,000
			70	19	50	140	300	550	1,100	1,800
			100	14	40	100	230	450	900	1,500
			16	19	48	130	270	560	1,100	1,700
			21	22	60	160	330	650	1,200	2,000
			31	19	50	140	300	550	1,100	1,800
			61	19	50	140	300	550	1,100	1,800
			91	14	40	100	230	450	900	1,500
Emergency Stop Torque $T_{2NOT}^{(2)}$	Nm	1,2	4~100	3 times of Nominal Output Torque						
Nominal Input Speed n_{iN}	rpm	1,2	4~100	5,000	5,000	4,000	4,000	3,000	3,000	2,000
Max. Input Speed n_{iB}	rpm	1,2	4~100	10,000	10,000	8,000	8,000	6,000	6,000	4,000
Micro Backlash P0	arcmin	1	4~10	-	-	≤1	≤1	≤1	≤1	≤1
		2	20~100	-	-	-	≤3	≤3	≤3	≤3
Reduced Backlash P1	arcmin	1	4~10	≤3	≤3	≤3	≤3	≤3	≤3	≤3
		2	20~100	≤5	≤5	≤5	≤5	≤5	≤5	≤5
Standard Backlash P2	arcmin	1	4~10	≤5	≤5	≤5	≤5	≤5	≤5	≤5
		2	20~100	≤7	≤7	≤7	≤7	≤7	≤7	≤7
Torsional Rigidity	Nm/arcmin	1,2	4~100	7	13	31	82	151	440	1,006
Max. Tilting Moment M_{2K}	Nm	1,2	4~100	55	75	190	300	1,300	2,930	5,500
Max. Axial Load $F_{2aB}^{(3)}$	N	1,2	4~100	990	1,050	2,850	2,990	10,590	16,660	29,430
Efficiency η	%	1	4~10	≥97%						
		2	20~100	≥94%						
Weight	kg	1	4~10	0.7	1.2	3.0	5.6	11.9	31.6	56.1
		2	20~100	1.0	1.6	3.7	7.3	15.9	36.9	70.4
Operating Temp	°C	1,2	4~100	-10°C~90°C						
Lubrication				Synthetic lubrication oils						
IP Level		1,2	4~100	IP65						
Mounting Position		1,2	4~100	all directions						
Noise ⁽⁴⁾	dB(A)	1,2	4~100	≤56	≤58	≤60	≤63	≤65	≤67	≤70

Gearbox Inertia

Model No.		Stage	Ratio ⁽¹⁾	AD047	AD064	AD090	AD110	AD140	AD200	AD255
Moments of Inertia J_i	kg · cm ²	1	4	0.03	0.14	0.51	2.87	7.54	25.03	58.31
			5	0.03	0.13	0.47	2.71	7.42	23.29	53.27
			7	0.03	0.13	0.45	2.62	7.14	22.48	50.97
			10	0.03	0.13	0.44	2.57	7.03	22.51	50.56
		2	20	0.03	0.03	0.13	0.47	2.71	7.42	23.29
			25	0.03	0.03	0.13	0.47	2.71	7.42	23.29
			35	0.03	0.03	0.13	0.47	2.71	7.42	23.29
			40	0.03	0.03	0.13	0.44	2.57	7.03	22.51
			50	0.03	0.03	0.13	0.44	2.57	7.03	22.51
			70	0.03	0.03	0.13	0.44	2.57	7.03	22.51
			100	0.03	0.03	0.13	0.44	2.57	7.03	22.51
			16	0.03	0.03	0.13	0.47	2.71	7.42	23.29
			21	0.03	0.03	0.13	0.47	2.71	7.42	23.29
			31	0.03	0.03	0.13	0.44	2.57	7.03	22.51
			61	0.03	0.03	0.13	0.44	2.57	7.03	22.51
			91	0.03	0.03	0.13	0.44	2.57	7.03	22.51

(1) Ratio ($i=N_{in}/N_{out}$)(2) Max. acceleration torque $T_{2B} = 60\%$ of T_{2NOT}

(3) Applied to the output shaft center at 100 rpm

(4) The dB values are measured by gearbox with ratio 10 (1-stage) or ratio 100 (2-stage), no loading at 3,000 RPM or at the respective Nominal Input Speed by bigger model size.

By lower ratio and/or higher RPM, the noise level could be 3 to 5 dB higher.

Dimensions (1-stage, Ratio $i=4\sim 10$) / AD Series

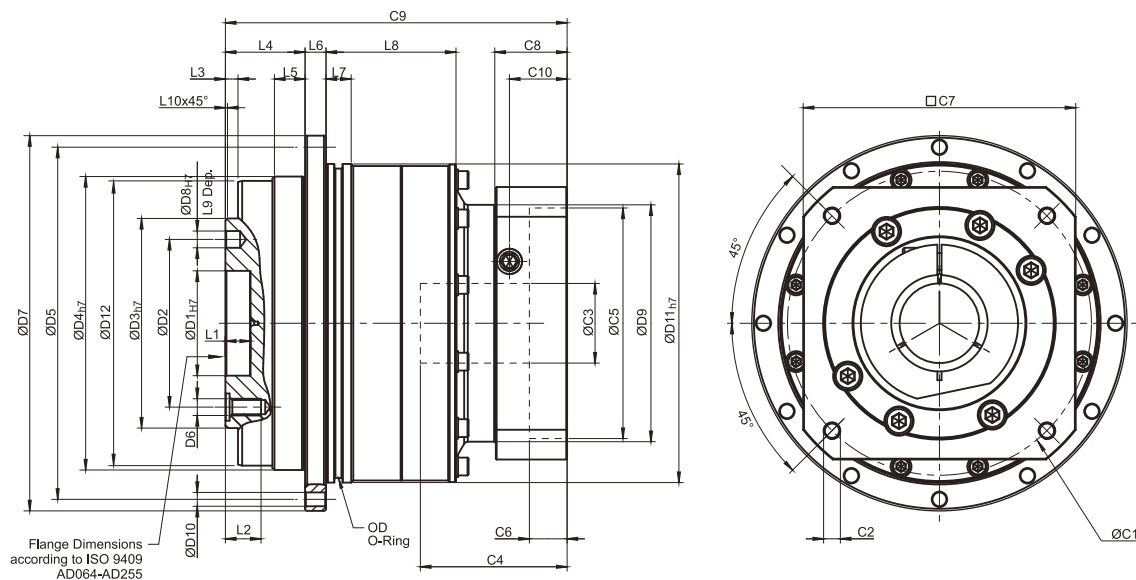

[unit: mm]

Dimension	AD047	AD064	AD090	AD110	AD140	AD200	AD255
D1 _{H7}	12	20	31.5	40	50	80	100
D2	20	31.5	50	63	80	125	140
D3 _{H7}	28	40	63	80	100	160	180
D4 _{H7}	47	64	90	110	140	200	255
D5	67	79	109	135	168	233	280
D6	4 x M3 x 0.5P	7 x M5 x 0.8P	7 x M6 x 1P	11 x M6 x 1P	11 x M8 x 1.25P	11 x M10 x 1.5P	12 x M16 x 2P
D7	72	86	118	145	179	247	300
D8 _{H7}	3	5	6	6	8	10	12
D9	45.5	55	77	90	113	138	175
D10	8 x 3.4	8 x 4.5	8 x 5.5	8 x 5.5	12 x 6.6	12 x 9	16 x 13.5
D11 _{H7}	60	70	95	120	152	212	255
D12	46.2	63.2	89.2	109.2	139.2	199.2	254.2
L1	4	8	12	12	12	16	20
L2	6.5	8	13.5	13.5	17	22.5	30.5
L3	3	3	6	6	6	8	12
L4	19.5	19.5	30	29	38	50	66
L5	7	7	10	10	14.6	15	20
L6	4	4	7	8	10	12	18
L7	5	7.7	8	10	12	15	20
L8	18.5	28.5	27	37	62	69.5	82
L9	4	6	7	7	7	10	10
L10	0.5	0.5	1	1	1	1	1
C1 ¹	46	70	100	130	165	215	235
C2 ¹	M4 x 0.7P	M5 x 0.8P	M6 x 1P	M8 x 1.25P	M10 x 1.5P	M12 x 1.75P	M12 x 1.75P
C3 ¹	≤11 / ≤12 ²	≤14 / ≤16 ²	≤19 / ≤24	≤32	≤38	≤48	≤55
C4 ¹	30	34	40	50	60	85	116
C5 ¹	30	50	80	110	130	180	200
C6 ¹	3.5	8	4	5	6	6	6
C7 ¹	48	60	90	115	142	190	220
C8 ¹	19.5	19	17	19.5	22.5	29	63
C9 ¹	70	82.5	99.5	121.5	151	199.5	256.5
C10 ¹	13.25	13.5	10.75	13	15	20.75	53.5
OD	56 x 2	66 x 2	90 x 3	110 x 3	145 x 3	200 x 5	238 x 5

1. C1~C10 are motor specific dimensions (metric std shown). Refer to www.apexdyna.com and Design Tool to view your specific motor mounting system.
 2. AD047 ratio 5, 10 offers C3 ≤ 12 option; AD064 ratio 5, 10 offers C3 ≤ 16 option.

Dimensions (2-stage, Ratio $i=20\sim 100$) / AD Series

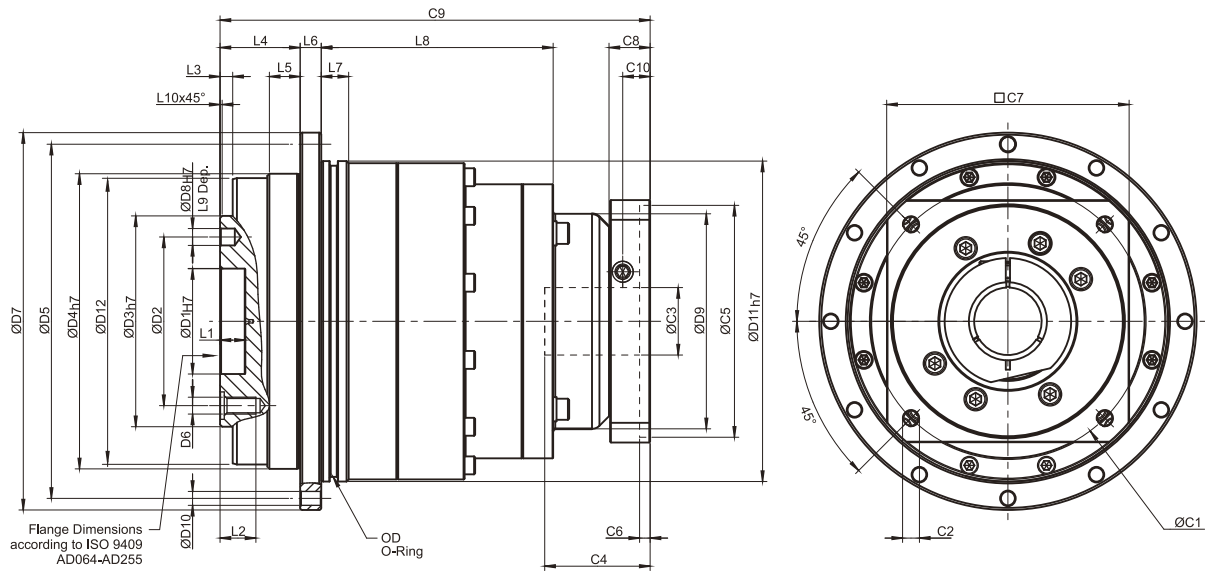

[unit: mm]

Dimension	AD047	AD064	AD090	AD110	AD140	AD200	AD255
D1 _{H7}	12	20	31.5	40	50	80	100
D2	20	31.5	50	63	80	125	140
D3 _{H7}	28	40	63	80	100	160	180
D4 _{H7}	47	64	90	110	140	200	255
D5	67	79	109	135	168	233	280
D6	4 x M3 x 0.5P	7 x M5 x 0.8P	7 x M6 x 1P	11 x M6 x 1P	11 x M8 x 1.25P	11 x M10 x 1.5P	12 x M16 x 2P
D7	72	86	118	145	179	247	300
D8 _{H7}	3	5	6	6	8	10	12
D9	45.5	45.5	53.4	77	102	125	160
D10	8 x 3.4	8 x 4.5	8 x 5.5	8 x 5.5	12 x 6.6	12 x 9	16 x 13.5
D11 _{H7}	60	70	95	120	152	212	255
D12	46.2	63.2	89.2	109.2	139.2	199.2	254.2
L1	4	8	12	12	12	16	20
L2	6.5	8	13.5	13.5	17	22.5	30.5
L3	3	3	6	6	6	8	12
L4	19.5	19.5	30	29	38	50	66
L5	7	7	10	10	14.6	15	20
L6	4	4	7	8	10	12	18
L7	5	7.7	8	10	12	15	20
L8	54.5	65	60	87.5	110	132.5	148
L9	4	6	7	7	7	10	10
L10	0.5	0.5	1	1	1	1	1
C1 ³	46	46	70	100	130	165	215
C2 ³	M4 x 0.7P	M4 x 0.7P	M5 x 0.8P	M6 x 1P	M8 x 1.25P	M10 x 1.5P	M12 x 1.75P
C3 ³	≤11 / ≤12	≤11 / ≤12	≤14 / ≤15.875 / ≤16	≤19 / ≤24	≤32	≤38	≤48
C4 ³	30	30	34	40	50	60	85
C5 ³	30	30	50	80	110	130	180
C6 ³	3.5	3.5	8	4	5	6	6
C7 ³	48	48	60	90	115	142	190
C8 ³	19.5	19.5	19	17	19.5	22.5	29
C9 ³	97.5	108	134	160	204	248	311.5
C10 ³	13.25	13.25	13.5	10.75	13	15	20.75
OD	56 x 2	66 x 2	90 x 3	110 x 3	145 x 3	200 x 5	238 x 5

3. C1-C10 are motor specific dimensions (metric std shown). Refer to www.apexdyna.com and Design Tool to view your specific motor mounting system.

Dimensions (2-stage, Ratio $i = 16 \sim 91$) / AD Series

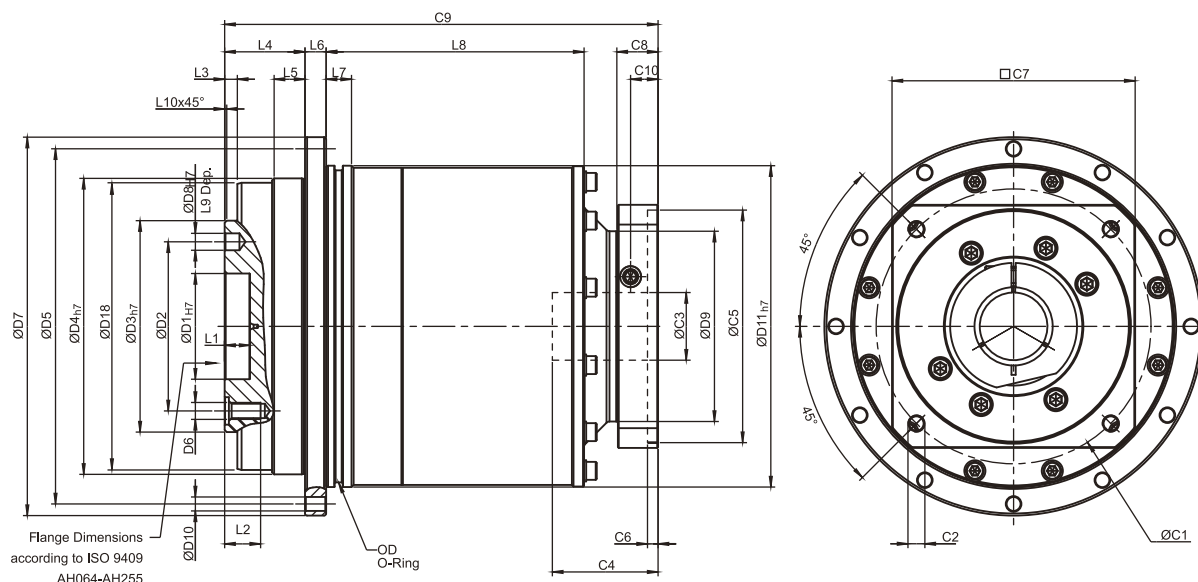

[unit: mm]

Dimension	AD047	AD064	AD090	AD110	AD140	AD200	AD255
D1 ^{H7}	12	20	31.5	40	50	80	100
D2	20	31.5	50	63	80	125	140
D3 ^{h7}	28	40	63	80	100	160	180
D4 ^{h7}	47	64	90	110	140	200	255
D5	67	79	109	135	168	233	280
D6	4 x M3 x 0.5P	7 x M5 x 0.8P	7 x M6 x 1P	11 x M6 x 1P	11 x M8 x 1.25P	11 x M10 x 1.5P	12 x M16 x 2P
D7	72	86	118	145	179	247	300
D8 ^{H7}	3	5	6	6	8	10	12
D9	45.5	45.5	55	77	90	113	138
D10	8 x 3.4	8 x 4.5	8 x 5.5	8 x 5.5	12 x 6.6	12 x 9	16 x 13.5
D11 ^{h7}	60	70	95	120	152	212	255
D18	46.2	63.2	89.2	109.2	139.2	199.2	254.2
L1	4	8	12	12	12	16	20
L2	6.5	8	13.5	13.5	17	22.5	30.5
L3	3	3	6	6	6	8	12
L4	19.5	19.5	30	29	38	50	66
L5	7	7	10	10	14.6	15	20
L6	4	4	7	8	10	12	18
L7	5	7.7	8	10	12	15	20
L8	52.5	28.5	32	37	122	79.5	82
L9	4	6	7	7	7	10	10
L10	0.5	0.5	1	1	1	1	1
C1 ^d	46	46	70	100	130	165	215
C2 ^d	M4 x 0.7P	M4 x 0.7P	M5 x 0.8P	M6 x 1P	M8 x 1.25P	M10 x 1.5P	M12 x 1.75P
C3 ^d	≤11 / ≤12	≤11 / ≤12	≤14 / ≤15.875 / ≤16	≤19 / ≤24	≤32	≤38	≤48
C4 ^d	30	30	34	40	50	60	85
C5 ^d	30	30	50	80	110	130	180
C6 ^d	3.5	3.5	8	4	5	6	6
C7 ^d	48	48	60	90	115	142	190
C8 ^d	19.5	19.5	19	17	19.5	22.5	29
C9 ^d	100	106	130.5	149	205	247.5	323
C10 ^d	13.25	13.25	13.5	10.75	13	15	20.75
OD	56 x 2	66 x 2	90 x 3	110 x 3	145 x 3	200 x 5	238 x 5

4. C1~C10 are motor specific dimensions (metric std shown). Refer to www.apexdyna.com and Design Tool to view your specific motor mounting system.

Specifications / ADR Series

Gearbox Performance

Model No.		Stage	Ratio ⁽¹⁾	ADR047	ADR064	ADR090	ADR110	ADR140	ADR200	ADR255	
Nominal Output Torque T_{2N}	Nm	1	4	19	48	130	270	560	1,100	1,700	
			5	22	60	160	330	650	1,200	2,000	
			7	19	50	140	300	550	1,100	1,800	
			10	14	60	160	325	650	1,200	2,000	
			14	-	42	140	300	550	1,100	1,800	
			20	-	40	100	230	450	900	1,500	
		2	20	19	-	-	-	-	-	-	-
			25	22	60	160	330	650	1,200	2,000	
			35	19	50	140	300	550	1,100	1,800	
			40	19	48	130	270	560	1,100	1,700	
			50	22	60	160	330	650	1,200	2,000	
			70	19	50	140	300	550	1,100	1,800	
			100	14	40	100	230	450	900	1,500	
			140	-	-	140	300	550	1,100	1,800	
200	-	-	100	230	450	900	1,500				
Emergency Stop Torque T_{2NOTB} ⁽²⁾	Nm	1,2	4~200	3 times of Nominal Output Torque							
Nominal Input Speed n_{1N}	rpm	1,2	4~200	5,000	5,000	4,000	4,000	3,000	3,000	2,000	
Max. Input Speed n_{1B}	rpm	1,2	4~200	10,000	10,000	8,000	8,000	6,000	6,000	4,000	
Micro Backlash P0	arcmin	1	4~20	-	-	≤2	≤2	≤2	≤2	≤2	
		2	25~200	-	-	≤4	≤4	≤4	≤4	≤4	
Reduced Backlash P1	arcmin	1	4~20	≤4	≤4	≤4	≤4	≤4	≤4	≤4	
		2	25~200	≤7	≤7	≤7	≤7	≤7	≤7	≤7	
Standard Backlash P2	arcmin	1	4~20	≤6	≤6	≤6	≤6	≤6	≤6	≤6	
		2	25~200	≤9	≤9	≤9	≤9	≤9	≤9	≤9	
Torsional Rigidity	Nm/arcmin	1,2	4~200	7	13	31	82	151	440	1,006	
Max. Tilting Moment M_{2K}	Nm	1,2	4~200	55	75	190	300	1,300	2,930	5,500	
Max. Axial Load F_{2aB} ⁽³⁾	N	1,2	4~200	990	1,050	2,850	2,990	10,590	16,660	29,430	
Efficiency η	%	1	4~20	≥95%							
		2	25~200	≥92%							
Weight	kg	1	4~20	1.1	2.1	5.9	10.5	21.9	50.9	85.4	
		2	25~200	1.4	1.9	4.5	9.8	20.1	45.4	85.9	
Operating Temp	°C	1,2	4~200	-10°C~90°C							
Lubrication				Synthetic lubrication oils							
IP Level		1,2	4~200	IP65							
Mounting Position		1,2	4~200	all directions							
Noise ⁽⁴⁾	dB(A)	1,2	4~200	≤61	≤63	≤65	≤68	≤70	≤72	≤74	

Gearbox Inertia

Model No.		Stage	Ratio ⁽¹⁾	ADR047	ADR064	ADR090	ADR110	ADR140	ADR200	ADR255	
Moments of Inertia J_i	kg · cm ²	1	4~10	0.09	0.35	2.25	6.84	23.4	68.9	135.4	
			14	-	0.31	1.87	6.25	21.8	65.6	119.8	
			20	-	0.31	1.87	6.25	21.8	65.6	119.8	
		2	20	0.09	-	-	-	-	-	-	-
			25~100	0.09	0.09	0.35	2.25	6.84	23.4	68.9	
			140~200	-	-	0.31	1.87	6.25	21.8	65.6	

(1) Ratio ($i=N_{in}/N_{out}$)

(2) Max. acceleration torque $T_{2B} = 60\%$ of T_{2NOT}

(3) Applied to the output shaft center at 100 rpm

(4) The dB values are measured by gearbox with ratio 10 (1-stage) or ratio 100 (2-stage), no loading at 3,000 RPM or at the respective Nominal Input Speed by bigger model size.

By lower ratio and/or higher RPM, the noise level could be 3 to 5 dB higher.

Dimensions (1-stage, Ratio $i=4\sim 20$) / ADR Series

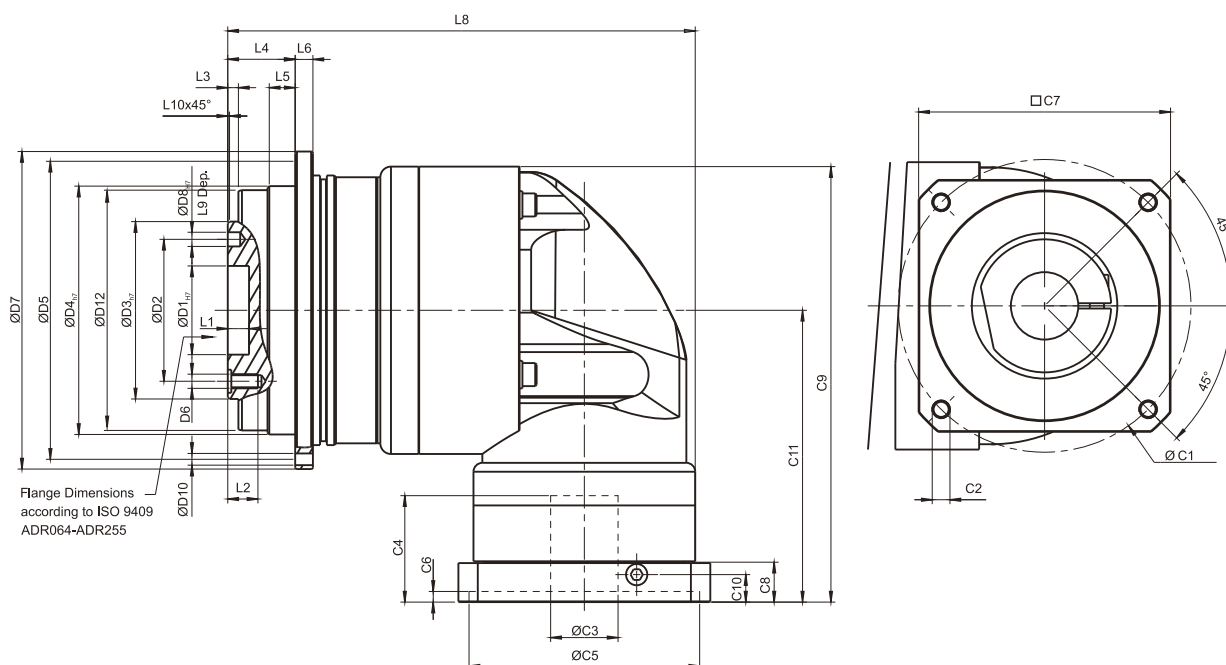

[unit: mm]

Dimension	ADR047	ADR064	ADR090	ADR110	ADR140	ADR200	ADR255
D1 _{H7}	12	20	31.5	40	50	80	100
D2	20	31.5	50	63	80	125	140
D3 _{h7}	28	40	63	80	100	160	180
D4 _{h7}	47	64	90	110	140	200	255
D5	67	79	109	135	168	233	280
D6	4 x M3 x 0.5P	7 x M5 x 0.8P	7 x M6 x 1P	11 x M6 x 1P	11 x M8 x 1.25P	11 x M10 x 1.5P	12 x M16 x 2P
D7	72	86	118	145	179	247	300
D8 _{H7}	3	5	6	6	8	10	12
D10	8 x 3.4	8 x 4.5	8 x 5.5	8 x 5.5	12 x 6.6	12 x 9	16 x 13.5
D12	46.2	63.2	89.2	109.2	139.2	199.2	254.2
L1	4	8	12	12	12	16	20
L2	6.5	8	13.5	13.5	17	22.5	30.5
L3	3	3	6	6	6	8	12
L4	19.5	19.5	30	29	38	50	66
L5	7	7	10	10	14.6	15	20
L6	4	4	7	8	10	12	18
L8	107.5	126	172.5	201	263.5	334.5	392
L9	4	6	7	7	7	10	10
L10	0.5	0.5	1	1	1	1	1
C1 ¹	46	70	100	130	165	215	235
C2 ¹	M4 x 0.7P	M5 x 0.8P	M6 x 1P	M8 x 1.25P	M10 x 1.5P	M12 x 1.75P	M12 x 1.75P
C3 ¹	≤11 / ≤12	≤14 / ≤16	≤19 / ≤24	≤32	≤38	≤48	≤55
C4 ¹	30	34	40	50	60	85	116
C5 ¹	30	50	80	110	130	180	200
C6 ¹	3.5	8	4	5	6	6	6
C7 ¹	48	60	90	115	142	190	220
C8 ¹	19.5	19	17	19.5	22.5	29	63
C9 ¹	104.25	116.5	159.5	199	245.5	316	398.5
C10 ¹	13.25	13.5	10.75	13	15	20.75	53.5
C11 ¹	74	81.5	107.5	134	164.5	213.5	268.5

1. C1~C10 are motor specific dimensions (metric std shown). Refer to www.apexdyna.com and Design Tool to view your specific motor mounting system.

Dimensions (2-stage, Ratio $i=25\sim 200$) / ADR Series

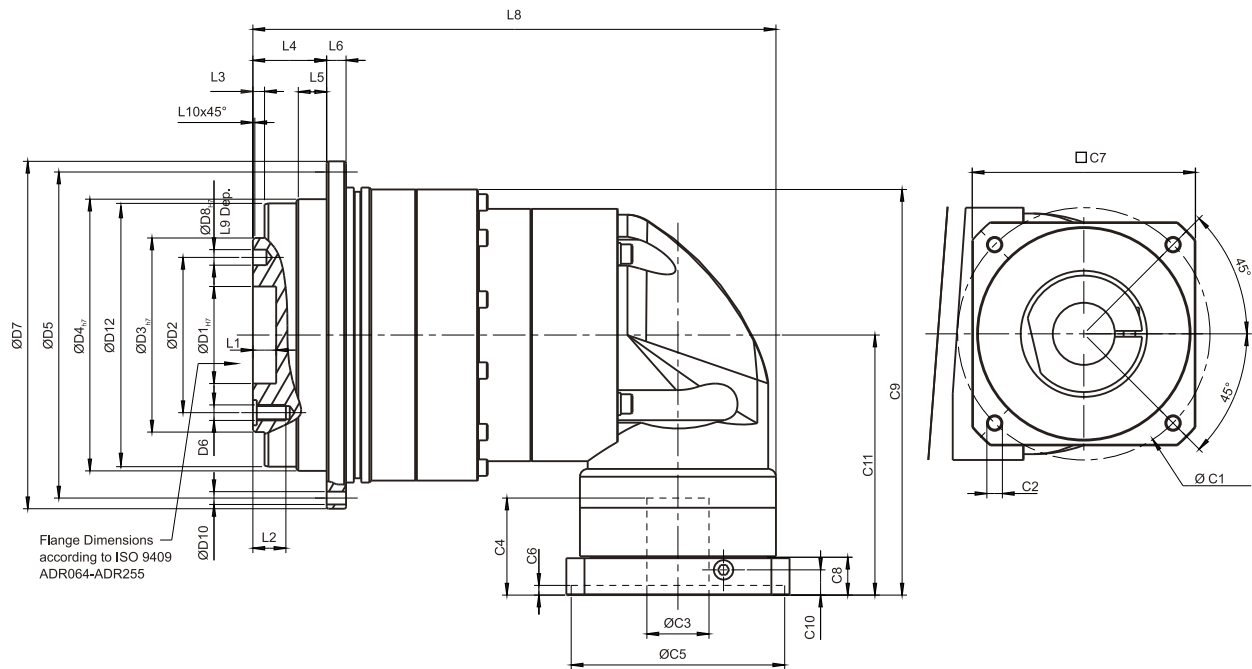

[unit: mm]

Dimension	ADR047	ADR064	ADR090	ADR110	ADR140	ADR200	ADR255
D1 _{H7}	12	20	31.5	40	50	80	100
D2	20	31.5	50	63	80	125	140
D3 _{h7}	28	40	63	80	100	160	180
D4 _{h7}	47	64	90	110	140	200	255
D5	67	79	109	135	168	233	280
D6	4 x M3 x 0.5P	7 x M5 x 0.8P	7 x M6 x 1P	11 x M6 x 1P	11 x M8 x 1.25P	11 x M10 x 1.5P	12 x M16 x 2P
D7	72	86	118	145	179	247	300
D8 _{H7}	3	5	6	6	8	10	12
D10	8 x 3.4	8 x 4.5	8 x 5.5	8 x 5.5	12 x 6.6	12 x 9	16 x 13.5
D12	46.2	63.2	89.2	109.2	139.2	199.2	254.2
L1	4	8	12	12	12	16	20
L2	6.5	8	13.5	13.5	17	22.5	30.5
L3	3	3	6	6	6	8	12
L4	19.5	19.5	30	29	38	50	66
L5	7	7	10	10	14.6	15	20
L6	4	4	7	8	10	12	18
L8	122	132.5	163	217.5	269.5	333.5	403
L9	4	6	7	7	7	10	10
L10	0.5	0.5	1	1	1	1	1
C1 ²	46	46	70	100	130	165	215
C2 ²	M4 x 0.7P	M4 x 0.7P	M5 x 0.8P	M6 x 1P	M8 x 1.25P	M10 x 1.5P	M12 x 1.75P
C3 ²	≤11 / ≤12	≤11 / ≤12	≤14 / ≤15.875 / ≤16	≤19 / ≤24	≤32	≤38	≤48
C4 ²	30	30	34	40	50	60	85
C5 ²	30	30	50	80	110	130	180
C6 ²	3.5	3.5	8	4	5	6	6
C7 ²	48	48	60	90	115	142	190
C8 ²	19.5	19.5	19	17	19.5	22.5	29
C9 ²	103.25	108.25	128.25	166.5	209	269.5	340
C10 ²	13.25	13.25	13.5	10.75	13	15	20.75
C11 ²	74	74	81.5	107.5	134	164.5	213.5

2. C1-C10 are motor specific dimensions (metric std shown). Refer to www.apexdyna.com and Design Tool to view your specific motor mounting system.

Specifications / ADS Series

Gearbox Performance

Model No.	Stage	Ratio ⁽¹⁾	ADS047	ADS064	ADS090	ADS110	ADS140	ADS200	ADS255	
Nominal Output Torque T_{2N}	1	4	19	48	130	270	560	1,100	1,700	
		5	22	60	160	330	650	1,200	2,000	
		7	19	50	140	300	550	1,100	1,800	
		10	14	40	100	230	450	900	1,500	
	2	16	19	48	130	270	560	1,100	1,700	
		21	22	60	160	330	650	1,200	2,000	
		31	19	50	140	300	550	1,100	1,800	
		61	19	50	140	300	550	1,100	1,800	
		91	14	40	100	230	450	900	1,500	
		Emergency Stop Torque $T_{2NOT}^{(2)}$	Nm	1,2	4~91	3 times of Nominal Output Torque				
Nominal Input Speed n_{1N}	rpm	1,2	4~91	5,000	5,000	4,000	4,000	3,000	3,000	2,000
Max. Input Speed n_{1B}	rpm	1,2	4~91	10,000	10,000	8,000	7,500	4,500	4,500	3,800
Micro Backlash P0	arcmin	1	4~10	-	-	≤1	≤1	≤1	≤1	≤1
		2	16~91	-	-	-	≤3	≤3	≤3	≤3
Reduced Backlash P1	arcmin	1	4~10	≤3	≤3	≤3	≤3	≤3	≤3	≤3
		2	16~91	≤5	≤5	≤5	≤5	≤5	≤5	≤5
Standard Backlash P2	arcmin	1	4~10	≤5	≤5	≤5	≤5	≤5	≤5	≤5
		2	16~91	≤7	≤7	≤7	≤7	≤7	≤7	≤7
Torsional Rigidity	Nm/arcmin	1,2	4~91	3	7	14	25	50	145	225
Max. Tilting Moment M_{2K}	Nm	1,2	4~91	55	75	190	300	1,300	2,930	5,500
Max. Axial Load	N	1,2	4~91	990	1,050	2,850	2,990	10,590	16,660	29,430
Input Max. Radial Load $F_{1RB}^{(3)}$	N	1	4~10	165	395	1,300	1,525	2,800	4,500	12,500
		2	16~91	165	165	395	1,300	1,525	2,800	4,500
Input Max. Axial Load $F_{1aB}^{(3)}$	N	1	4~10	580	1,000	1,100	980	2,700	4,700	8,000
		2	16~91	580	580	1,000	1,100	980	2,700	4,700
Efficiency η	%	1	4~10	≥97%						
		2	16~91	≥94%						
Weight	kg	1	4~10	0.8	1.4	3.4	6.7	13.5	35.0	63.8
		2	16~91	1.1	1.6	4.0	7.3	16.6	36.4	74.7
Operating Temp	°C	1,2	4~91	-10°C~90°C						
Lubrication				Synthetic lubrication oils						
IP Level		1,2	4~91	IP65						
Mounting Position		1,2	4~91	all directions						
Noise ⁽⁴⁾	dB(A)	1,2	4~91	≤56	≤58	≤60	≤63	≤65	≤67	≤70

Gearbox Inertia

Model No.	Stage	Ratio ⁽¹⁾	ADS047	ADS064	ADS090	ADS110	ADS140	ADS200	ADS255
Moments of Inertia J_1	1	4	0.06	0.21	0.87	3.65	10.27	43.05	102.68
		5	0.06	0.21	0.83	3.53	10.17	41.76	99.12
		7	0.06	0.21	0.82	3.47	9.99	41.15	97.41
		10	0.06	0.21	0.81	3.45	9.93	40.97	97.03
	2	16	0.06	0.06	0.21	0.83	3.53	10.17	41.76
		21	0.06	0.06	0.21	0.83	3.53	10.17	41.76
		31	0.06	0.06	0.21	0.83	3.53	10.17	41.76
		61	0.06	0.06	0.21	0.81	3.45	9.93	40.97
		91	0.06	0.06	0.21	0.81	3.45	9.93	40.97

(1) Ratio ($i=N_{in}/N_{out}$)

(2) Max. acceleration torque $T_{2B} = 60\%$ of T_{2NOT}

(3) Applied to the output shaft center at 100 rpm

(4) The dB values are measured by gearbox with ratio 10 (1-stage) or ratio 100 (2-stage), no loading at 3,000 RPM or at the respective Nominal Input Speed by bigger model size.

By lower ratio and/or higher RPM, the noise level could be 3 to 5 dB higher.

Dimensions (2-stage, Ratio $i = 16 \sim 91$) / ADS Series

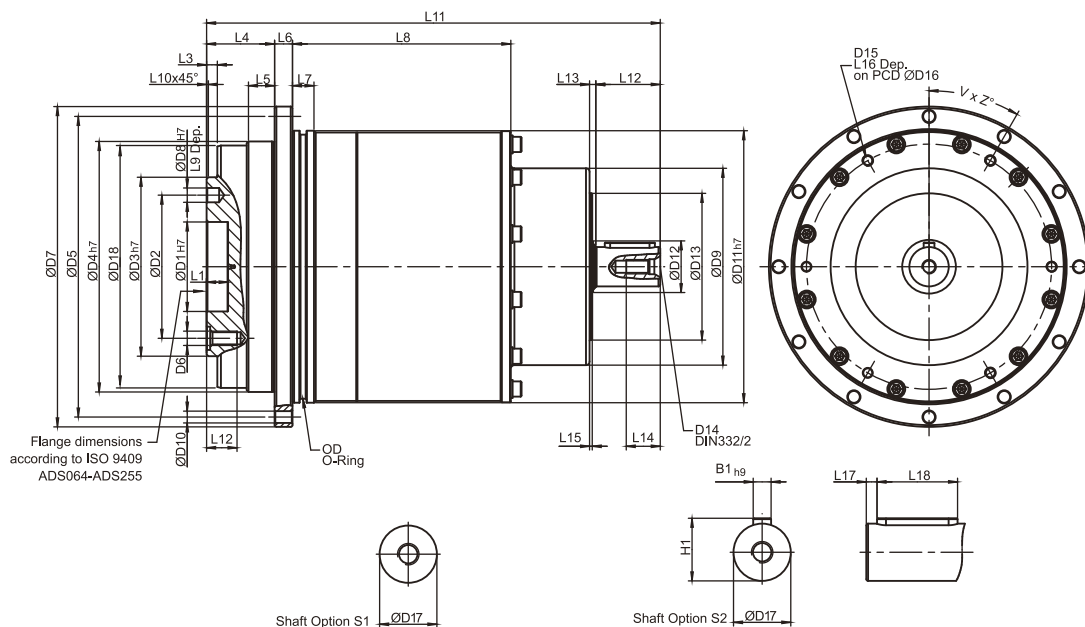

[unit: mm]

Dimension	ADS047	ADS064	ADS090	ADS110	ADS140	ADS200	ADS255
D1 _{H7}	12	20	31.5	40	50	80	100
D2	20	31.5	50	63	80	125	140
D3 _{H7}	28	40	63	80	100	160	180
D4 _{H7}	47	64	90	110	140	200	255
D5	67	79	109	135	168	233	280
D6	4 x M3 x 0.5P	7 x M5 x 0.8P	7 x M6 x 1P	11 x M6 x 1P	11 x M8 x 1.25P	11 x M10 x 1.5P	12 x M16 x 2P
D7	72	86	118	145	179	247	300
D8 _{H7}	3	5	6	6	8	10	12
D9	43	48	68	86	110	132	182
D10	8 x 3.4	8 x 4.5	8 x 5.5	8 x 5.5	12 x 6.6	12 x 9	16 x 13.5
D11 _{H7}	60	70	95	120	152	212	255
D12	22	22	22	22	30	40	75
D13	37	37	50	62	82	108	145
D14	M4 x 0.7P	M4 x 0.7P	M4 x 0.7P	M5 x 0.8P	M8 x 1.25P	M12 x 1.75P	M16 x 2P
D15	M3 x 0.5P	M3 x 0.5P	M4 x 0.7P	M5 x 0.8P	M6 x 1P	M8 x 1.25P	M10 x 1.5P
D16	51.5	61.5	84	107	137	193	235
D17 _{K6}	11	11	14	16	22	32	40
D18	46.2	63.2	89.2	109.2	139.2	199.2	254.2
L1	4	8	12	12	12	16	20
L2	6.5	8	13.5	13.5	17	22.5	30.5
L3	3	3	6	6	6	8	12
L4	19.5	19.5	30	29	38	50	66
L5	7	7	10	10	14.6	15	20
L6	4	4	7	8	10	12	18
L7	5	7.7	8	10	12	15	20
L8	62.5	63.5	67	82	122	79.5	177
L9	4	6	7	7	7	10	10
L10	0.5	0.5	1	1	1	1	1
L11	119.5	125.5	158.5	188	253.5	314.5	419.5
L12	18	18	22	28	36	58	82
L13	2.5	2.5	2.5	3.5	3.5	3.5	4.5
L14	10	10	10	12.5	19	28	36
L15	1.5	1.5	1.5	1.5	1.5	1.5	1.5
L16	5.5	5.5	7	9	11	14	18
L17	2	2	2	3	3	6	6
L18	14	14	18	22	28	45	70
B1 _{H9}	4	4	5	5	6	10	12
H1	12.5	12.5	16	18	24.5	35	43
OD	56 x 2	66 x 2	90 x 3	110 x 3	145 x 3	200 x 5	238 x 5
V	4	4	4	4	6	6	6
Z	45	45	45	45	30	30	30

Output Dimensions

**AD 047
ADR 047
ADS 047**

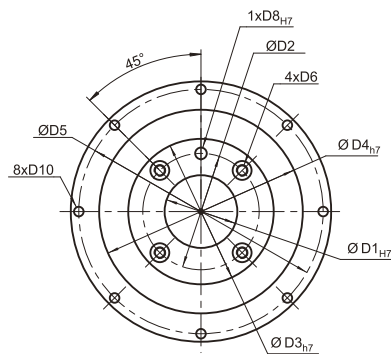

**AD 064 / AD 090
ADR 064 / ADR 090
ADS 064 / ADS 090**

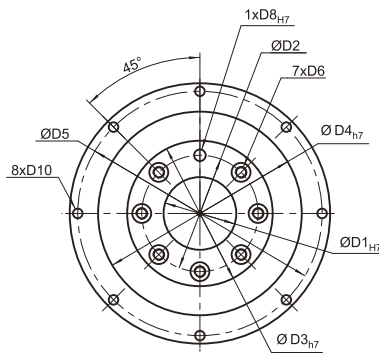

**AD 110
ADR 110
ADS 110**

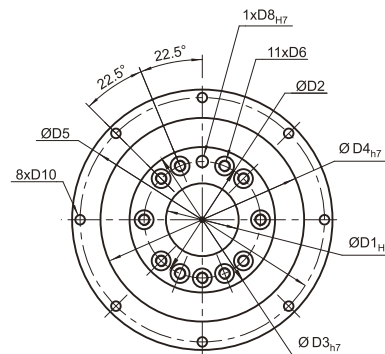

**AD 140 / AD 200
ADR 140 / ADR 200
ADS 140 / ADS 200**

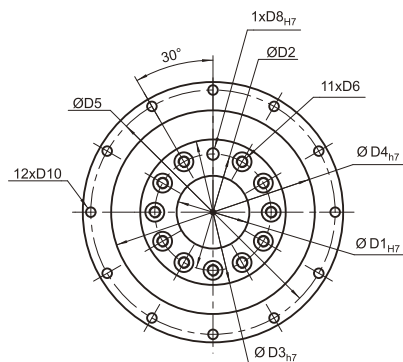

**AD 255
ADR 255
ADS 255**

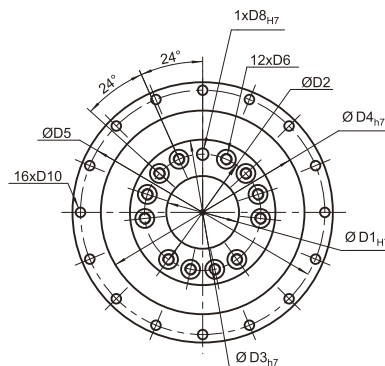

[unit: mm]

Dimension	AD047	AD064	AD090	AD110	AD140	AD200	AD255
	ADR047	ADR064	ADR090	ADR110	ADR140	ADR200	ADR255
	ADS047	ADS064	ADS090	ADS110	ADS140	ADS200	ADS255
D1 _{H7}	12	20	31.5	40	50	80	100
D2	20	31.5	50	63	80	125	140
D3 _{h7}	28	40	63	80	100	160	180
D4 _{h7}	47	64	90	110	140	200	255
D5	67	79	109	135	168	233	280
D6	M3 x 0.5P	M5 x 0.8P	M6 x 1P	M6 x 1P	M8 x 1.25P	M10 x 1.5P	M16 x 2P
D8 _{H7}	3	5	6	6	8	10	12
D10	3.4	4.5	5.5	5.5	6.6	9	13.5

Max. Tilting Moment M_{2K}

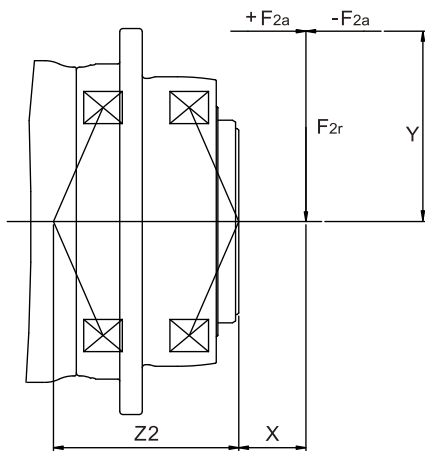

$$M_{2K} = \frac{F_{2a} * Y + F_{2r} * (X+Z2)}{1000}$$

M_{2K} : [Nm]
 F_{2a}, F_{2r} : [N]
 $X, Y, Z2$: [mm]

AD / ADR / ADS	047	064	090	110	140	200	255
Z2 [mm]	37.9	46.2	63.1	75.5	92.2	119.2	148.8

Note : Applied to the output flange center at 100 rpm.

ADS-Permitted Radial and Axial Loads

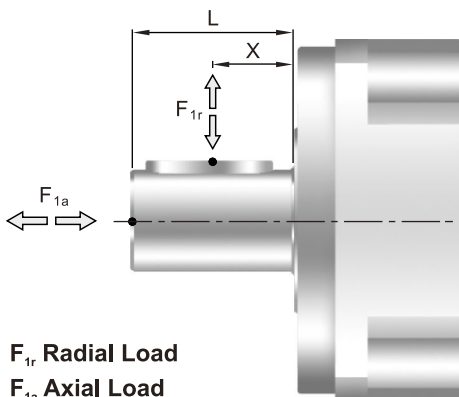

The permitted radial and axial loads on input shaft of the gearbox depend on the design of the gearbox supporting bearings. APEX use the extension straddle oversized ball bearing design. It can take heavy load from both axes.

F_{1r} Radial Load
 F_{1a} Axial Load

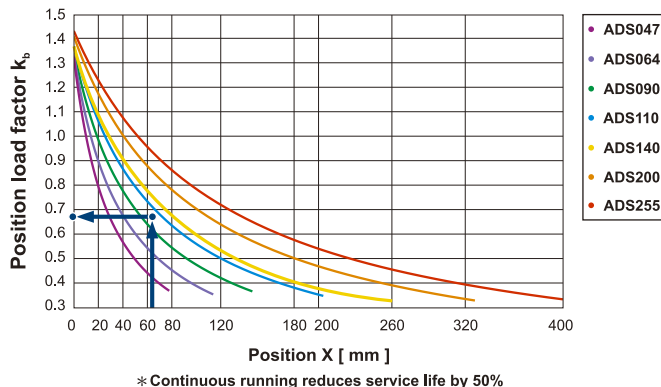
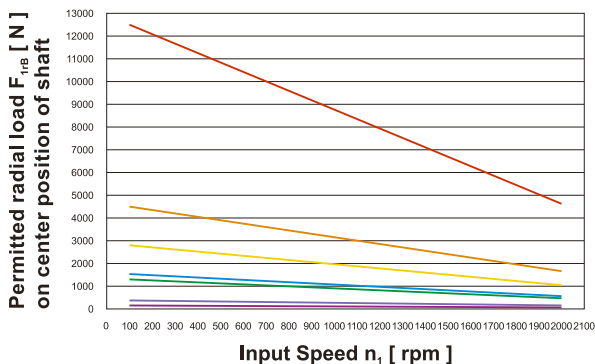

If radial force F_{1r} is exert on the center of the output shaft $X=1/2 \times L$. The permitted radial load is given on above diagram.

If radial force F_{1r} is not exert on the center of the output shaft $X < 1/2 \times L$ or $X > 1/2 \times L$. The permitted radial and axial loads can be calculated by the position load factor K_b on the above diagram.

Selection of the optimum gearbox

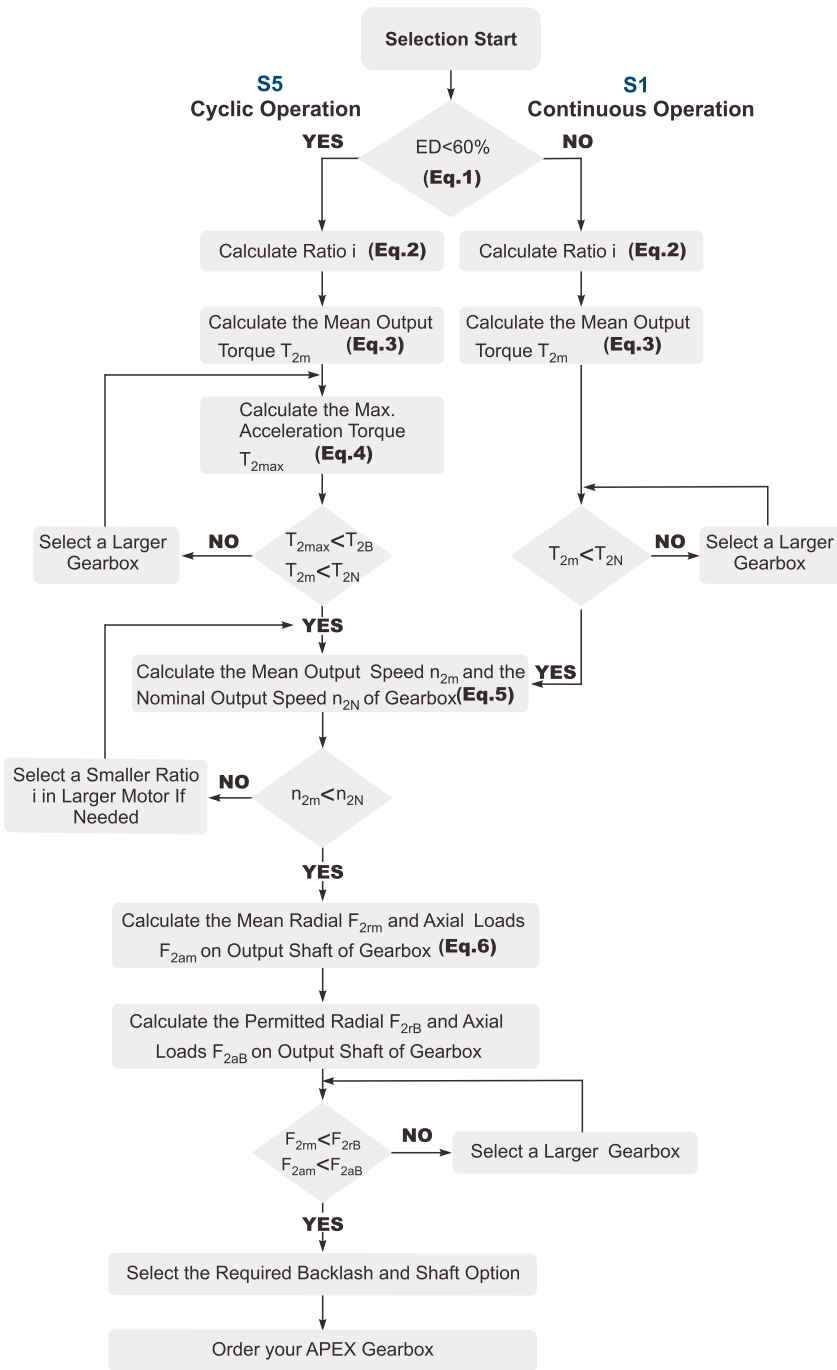

Recommended (for S5 Cycle Operation)

The general design is given for

$$\frac{J_L}{i^2} \leq 4 \times J_m$$

The optimal design is given for

$$\frac{J_L}{i^2} \cong J_m$$

J_L Load Inertia

J_m Motor Inertia

Liability Disclaimer:

APEX DYNAMICS, INC. endeavors to ensure the accuracy and reliability of the data in catalog.

APEX accepts no liability, whether in any form, for any loss or damage arising from any inaccuracy or omissions of this catalog.

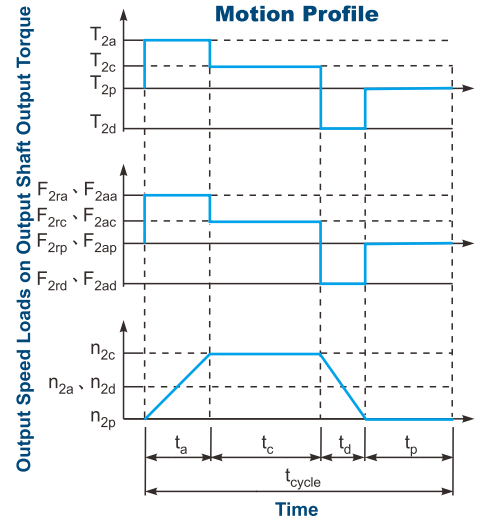

$$1. ED = \frac{t_a + t_c + t_d}{t_{cycle}} \times 100\% .$$

Index : a. Acceleration, c. Constant,
d. Deceleration, p. Pause (Eq. 1)

$$2. i \cong \frac{n_m}{n_{work}}$$

n_m Output Speed of the Motor
 n_{work} Working Speed (Eq. 2)

$$3. T_{2m} = \sqrt[3]{\frac{n_{2a} \times t_a \times T_{2a}^3 + n_{2c} \times t_c \times T_{2c}^3 + n_{2d} \times t_d \times T_{2d}^3}{n_{2a} \times t_a + n_{2c} \times t_c + n_{2d} \times t_d}}$$

(Eq. 3)

$$4. T_{2max} = T_{mB} \times i \times K_s \times \eta$$

where K_s is

K_s	No. of Cycles / hr
1.0	0 ~ 1,000
1.1	1,000 ~ 1,500
1.3	1,500 ~ 2,000
1.6	2,000 ~ 3,000
1.8	3,000 ~ 5,000

T_{mB} Max. Output Torque of the Motor

η Efficiency of the Gearbox (Eq. 4)

$$5. n_{2a} = n_{2d} = \frac{1}{2} \times n_{2c}$$

$$n_{2m} = \frac{n_{2a} \times t_a + n_{2c} \times t_c + n_{2d} \times t_d}{t_a + t_c + t_d}$$

$$n_{2N} = \frac{n_{1N}}{i}$$

(Eq. 5)

$$6. F_{2m} = \sqrt[3]{\frac{n_{2a} \times t_a \times F_{2ra}^3 + n_{2c} \times t_c \times F_{2rc}^3 + n_{2d} \times t_d \times F_{2rd}^3}{n_{2a} \times t_a + n_{2c} \times t_c + n_{2d} \times t_d}}$$

$$F_{2am} = \sqrt[3]{\frac{n_{2a} \times t_a \times F_{2aa}^3 + n_{2c} \times t_c \times F_{2ac}^3 + n_{2d} \times t_d \times F_{2ad}^3}{n_{2a} \times t_a + n_{2c} \times t_c + n_{2d} \times t_d}}$$

(Eq. 6)

Note



**APEX TAIWAN NORTH
ANDTEK AUTOMATION CO.,LTD**
TEL +886-02-82262655
13F-5, NO.2, Jian 8th Rd., Jhonghe Dist., New
Taipei City 235, TAIWAN
sales@andtek.com.tw
www.apexdyan.com



**APEX TAIWAN CENTRAL
ANDTEK AUTOMATION CO.,LTD**
TEL +886-04-23594286
9F-6, NO.925, Sec.4, Taiwan Blvd., Xitun Dist.
Taichung City 407, TAIWAN
sales@andtek.com.tw
www.apexdyan.com



**APEX TAIWAN SOUTH
MEN JENN ELECTRIC CO., LTD.**
TEL +886-06-2337332*6
NO.774, Zhonghua Rd., Yongkang Dist., Tainan
City 710, TAIWAN
menjenn@ms24.hinet.net
www.apexdyan.com



APEX TAIWAN INC. SHANGHAI
TEL +86-21-69220577
NO.128 ZHUUYING Road QINGPU Industry Area,
Shanghai, CHINA
sales@apexdyna.cn
www.apexdyan.cn



APEX DYNAMICS SHENZHEN, LTD.
TEL +86-755-84516325
NO. 1102A of D area, CFG mansion, Bao Yuan
Road, Bao' an District, Shenzhen, CHINA.
sales@szapexdyna.com
www.szapexdyna.com



APEX DYNAMICS BEIJING, LTD.
TEL +86-10-69570691
NO. 1, Yao Ping Road, Song Zhuang Town, Tongzhou
District, Beijing, CHINA.
bjapexdyna@163.com
www.bjapex.cn



CHONGQING APEX DYNAMICS CO., LTD.
TEL +86-23-67686860
406, Building 5, NO. 68, Jinyu Avenue, Beibu New
Area, Chongqing, CHINA
sales@cqapexdyna.com
www.apexdyna.com



APEX (XIAMEN) DYNAMICS TECHNOLOGY CO., LTD.
TEL +86-0592-720-5279
Unit B-3, 1F., NO. 129, Jingquan Road, Jimei District,
Xiamen, Fujian, CHINA
sales@xmapexdyan.com
www.xmapexdyna.com



APEX DYNAMICS USA, INC.
TEL +1-631-2449040
885 Marconi Avenue Ronkonkoma, NY 11779
U.S.A.
sales@apexdynamicsusa.com
www.apexdynamicsusa.com



APEX DYNAMICS KOREA INC
TEL +82-31-8179992
7-5, Aenigol-gil, Ilsandong-gu, Goyang-si, Gyeonggi-do,
Republic of Korea 10301
sales@apexdynakorea.co.kr
www.apexdynakorea.co.kr



APEX DYNAMICS JAPAN
TEL +88-092-4511202
1-3-46, Hamnichibasi, Hakata-ku, Fukuoka,
812-0897, JAPAN
sales@apexdyna.jp
www.apexdyna.jp



APEX DYNAMICS SINGAPORE PTE LTD
TEL +34-93-6562228
3 South Buona Vista Road, #05-15 & #06-15.
SINGAPORE 118136
sales@apexdyna.com.sg
www.apexdyna.com.sg



APEX DYNAMICS (THAILAND) CO., LTD.
TEL +66-2-326623
87 Soi Ladkrabang 30, Ladkrabang, Ladkrabang,
Bangkok 10520, Thailand
Apexthai2010@gmail.com
www.apexdyna.co.th



APEX DYNAMICS BV
TEL +31-492-509995
Churchillaan 101 5705 BK Helmond, NETHERLANDS
sales@apexdyna.nl
www.apexdyna.be



**APEX DYNAMICS
POLSKA SP. Z O.O.**
TEL +48-12-6304728
Ul. Krakowska 50, 32-083 Balice, Poland
sales@apexdyna.pl
www.apexdyna.pl



APEX DYNAMICS SPAIN, S.L.
TEL +34-93-6562290
Poligono Industrial Moli dels Freres, Calle C nº
12,08620-Sant Vicenç dels Horts, Barcelona, SPAIN
apexdyna@apexdyna.es
www.apexdyna.es



Big Diamond Trading Company LLC
TEL +968-94268885
2nd floor, Regus, Tamimah building, Al
Wattayah, Muscat, Oman
ar.gorji@diamondtradings.com



APEKS DINAMIK REDUKTOR DISLI SAN TIC AS
TEL +90-232-4589960
10053 SOKAK NO: 9 A.O.S.B. CIGLI- IZMIR - TURKEY
sales@apexdyna.com.tr
www.apexdyna.com.tr



APEX DYNAMICS AUSTRALIA PTY LTD.
TEL +613-95-852739
36 Taunton Drive,Cheltenham, Victoria 3192
AUSTRALIA
sales@apexdyna.com.au
www.apexdyna.com.au



APEX DYNAMICS (I) JV
TEL +91-9607927142
Shop No. 02, S. No. 100/5, Pune-Satara Highway,
Ambegaon Khurd, Pune-411046 Maharashtra, India
sales@apexdyna.co.in
www.apexdyna.co.in



APEX DYNAMICS FRANCE SAS
TEL +33-160-135097
11 - Burospace - 91570 - Bièvres, France
info@apexdyna.fr
www.apexdyna.fr



APEX DYNAMICS SWEDEN AB
TEL +46-75-2424444
Fredrikbergsgatan 2 SE-573 92 Tranås, SWEDEN
sales@apexdyna.se
www.apexdyna.se



PT.APEX DYNAMICS INDONESIA
TEL +62 21 2928 3681
Rukan Aralia Blok HY43 no.11, Harapan Indah II,
Bekasi - Jawa Barat, INDONESIA 17214
sales@apexdyna.co.id
www.apexdyna.co.id



APEX DYNAMICS GERMANY GMBH
TEL +49-7171 798069-0
Marie-Curie-Straße 25 D-73529 Schwäbisch Gmünd
werner.langer@apexdynamics.de
www.apexdynamics.de



APEX DYNAMICS CZECH S.R.O.
TEL +420-577-663877
tř. Tomáše Bati 1851 765 02 Otrokovice Česká
REPUBLIKA
info@apexdynaczech.cz
www.apexdynaczech.cz



APEX DYNAMICS РОССИЯ
TEL +7-495-2255452
TEL +7-495-6462422
г.Москва,ул. Южнопортовая, дом 7, строение
"С", 3-й этаж
info@apexdynarussia.ru
www.apexdynarussia.ru



APEX DYNAMICS MIDLANDS LTD
TEL +44-0121-737-1170
Heath House, Cheadle Rd, Uttoxeter,
ST14 7BY, UK
mikeg@apexdynauk.com
www.apexdynauk.com



APEX DYNAMICS SWITZERLAND AG
TEL +41-55-4517020
Obergasse 40, CH-8854 Galgenen, Switzerland
info@apexdyna.ch
www.apexdyna.ch



APEX DYNAMICS MOTION (M) SDN BHDTEL
TEL +60 7237 1055
Block A1-2, #35-03, Mercu 1 Jalan Tanjung Puteri 1,
R & F Tanjung Puteri, Johor Bahru 80300, Johor.
sales@apexdyna.com.sg
www.apexdyna.com.sg



APEX DYNAMICS BRAZIL
TEL +55-47-30298700
Rua Senador Petrônio Portela, 47-Bloco 5, Zona
Industrial Norte-CEP 89218-575-Joinville (SC)
luciano@neoyama.com.br
adriano.tuarte@neoyama.com.br
www.neoyama.com.br



APEX DYNAMICS ITALY SRL
TEL +39 02 36634521
VIA E. DE AMICIS, 2-20091 BRESSO (MI)
info@apexdynamics.it
www.apexdynamics.it



APEX DYNAMICS AUSTRIA GmbH
TEL +43 720788416
Dr. Hans-Lechner-Strasse 6,
5071 Wals-Siezenheim
info@apexdynamics.at
www.apexdynamics.at



UAB "APEKSO DINAMIKA"
TEL +370 52078165
Medaus g. 28A,
Medininuku k., Vilnius r. Sav.
LT-13192
info@apexdyna.lt



APEX DYNAMICS DENMARK
TEL +45 73121260
Grundtvigs Allé 165, 6400
Sønderborg, Denmark
sales@apexdyna.dk
www.apexdyna.dk



APEX DYNAMICS ISRAEL
TEL +972-3-6470471
17 Hamefalsim St., Kiryat Arye,
Petach-Tikva 4951447
Sales@apexdynamics.co.il
www.apexdynamics.co.il



APEX DYNAMICS SLOVAKIA S.R.O.
TEL +421919400476
Trenčianska cesta 887/52, 957 01
Bánovce nad Bebravou, Slovak republic
office@apexdyna.sk
www.apexdyna.sk



APEX DYNAMICS, INC.

No10. Keyuan 3rd RD.Situn District, Taichung City 40763, Taiwan (R.O.C)
Tel:886-4-24650219 | Fax:886-4-24650118
sales@apexdyna.com | [h?p://www.apexdyna.com](http://www.apexdyna.com)

APEX-2022-11-AD/ADR/ADS SERIES-1.0-TWN

Printed in Taiwan

